

# TRANSOM CRANES model 3010/23/24/26/30/31/34/35/36

## loading capacity 300 to 1000 Kg

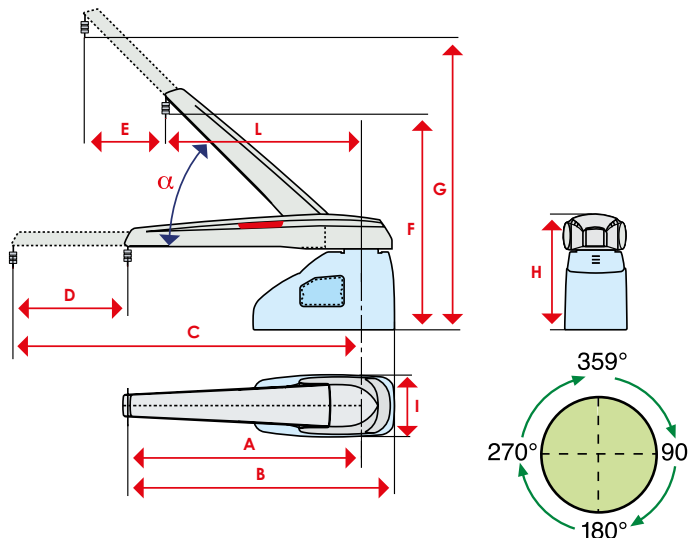

model	A (mm/ inch)	B (mm/ inch)	C (mm/ inch)	D (mm/ inch)	E (mm/ inch)	F (mm/ inch)	G (mm/ inch)	H (mm/ inch)	I (mm/ inch)	L (mm/ inch)	α	Cable lenght (mm/ inch)	Capacity standard (kg/ lbs)	Capacity optional (kg/ lbs)	Weight (kg/ lbs)
3010/37	2100 83"	2480 98"	3330 131"	1230 48"	785 31"	1810 71"	2765 109"	900 35"	460 18"	1590 62"	50°	6700/264" 5400/213"	300/660	450/1000 600/1320	400/880
3010/41	2300 90"	2690 106"	3720 146"½	1440 57"	920 36"	2000 79"	3080 121"	900 35"	460 18"	1715 68"	50°	7700/303" 6200/244"	300/660	450/1000 600/1320	439/970
3030/29	1750 69"	1980 78"	2600 102"	850 33"	600 24"	1560 61"	2165 85"¼	856 34"	460 18"	1425 56"	50°	4400 173" 3500 138"	300/660	450/1000 600/1320	338/740
3030/33	1860 73"	2130 84"	2890 114"	1030 41"	660 26"	1810 71"	2605 102"	856 34"	460 18"	1530 60"	50°	5700 224" 4600 181"	300/660	450/1000 600/1320	378/770
3030/42	2430 96"	2730 107"	3930 155"	1500 59"	950 37"	2100 83"	3260 128"	856 34"	460 18"	1840 73"	53°	7700 303" 6200 244"	300/660	450/1000 600/1320	440/970
3030/45	2630 104"	2930 115"	4230 167"	1600 63"	1015 40"	2250 89"	3490 137"	856 34"	460 18"	1965 78"	53°	7700 303" 6200 244"	300/660	500/1100	465/1020
3010V39	2470 97"	3020 119"	3920 154"	1450 57"	930 37"	1330 52"	2434 96"	705 27"¾	360 14"¾	1780 70"	50°	11000 433"	300/660	600/1320	350/770
3031/52	3045 120"	3280 129"	5095 201"	2050 81"	1450 57"	2800 110"	4250 167"	1000 39"¾	460 18"	2230 88"	45°	6200 244"	350/770	--	440/970
3034/28	1395 55"	1730 68"	2525 100"	1130 45"	630 25"	1730 68"	2665 105"	780 30"¾	480 19"	710 28"	53°	4000 158"	400/880	--	405/890
3035/42	2620 103"	2800 110"	4220 166"	1600 63"	915 36"	2420 95"	3740 147"	510 20" 570 22"	473 19"	1390 55"	56°	6800 268" 5400 213"	400/900	500/1200	367/810 378/830
3031/29	1815 72"	2050 81"	2715 107"	900 36"	640 25"	2090 82"	2730 107"	1000 39"¾	460 18"	1360 53"½	45°	3500 138"	500/1100	--	312/690
3031/33	2010 79"	2250 89"	3110 122"	1100 43"	780 31"	2230 88"	3010 118"	1000 39"¾	460 18"	1430 56"¾	45°	4600 181"	500/1100	--	334/740
3031/37	2015 80"	2250 89"	3315 130"	1300 51"	920 36"	2370 93"	3290 130"	1000 39"¾	460 18"	1570 61"¾	45°	5400 213"	500/1100	--	355/780
3031/41	2690 106"	2950 116"	4020 158"	1400 55"	990 39"	2560 101"	3550 140"	1000 39"¾	460 18"	1885 74"	45°	6200 244"	500/1100	--	378/830
3034/24	1150 45"	1490 59"	2050 81"	900 35"	505 20"	1540 61"	2285 90"	780 30"¾	480 19"	570 22"¾	56°	4000 158"	500/1100	--	388/850
3023/45	2400 94"	2720 107"	4200 165"	1830 72"	1250 49"	1900 75"	3240 128"	1020 40"	500 20"	1950 76"	47°	5400 213"	500/1100	--	607/1340
3023/51	2800 110"	3130 123"	4850 191"	2050 81"	1350 53"	2250 89"	3700 146"	1020 40"	500 20"	2200 86"	47°	6200 244"	500/1100	--	680/1500
3024/60	2490 98"	3090 122"	6000 236"	3525 139"	2020 79"½	2620 103"¾	5475 215"½	880 35"	575 22"¾	1500 59"	55°	4000 158"	500/1100	--	850/1880
3036/43	2490 98"	2790 110"	4040 159"	1550 61"	900 35"	2290 90"	3685 145"	770 30"¾ 1117 44"	460 18"	1250 49"	56°	6200 244"	500/1100	--	334/740
3024/40	1700 67"	1955 77"	4595 180"¾	2895 114"	1350 53"¾	2070 81"½	4240 167"	880 34"¾	575 22"¾	950 37"¾	55°	5700" 224"	700/1545	--	610/1345
3024/45	1990 78"	2320 91"	4600 181"	2830 111"¾	1450 57"	2100 82"¾	4240 167"	880 35"	470 18"½	990 39"	56°	4000 158"	700/1550	--	720/1590
3026/40	2400 94"	2730 107"	3725 147"	1330 52"¾	925 36"	2060 81"	3000 118"	1020 40"	500 20"	1900 75"	47°	6000 236"	800/1800	1000/2200	562/1240
3026/47	2800 110"	3050 120"	4400 173"	1600 63"	1075 42"	2350 92"	3520 138"	1020 40"	500 20"	2100 83"	47°	6000 236"	800/1800	1000/2200	606/1340
3026/60	3560 140"	3860 152"	5700 224"	2140 84"	1500 59"	3050 120"	4600 181"	1020 40"	500 20"	2660 105"	47°	7200 283"	800/1800	--	789/1740

To choose the base, please refer to section:  
 For model 3010/3023/3026/3030/3035/3036 "SLEWING FLYBRIDGE CRANE BASES"  
 For model 3023/3026 \* F, G dimensions are referred to installation on AL base.  
 Standard rotation 359°.